

Reyrolle
Protection
Devices

7PG26 DAD

High Impedance Relays

Answers for energy

SIEMENS

SIEMENS
siemens-russia.com

Contents

Technical Manual Chapters

1. Description of Operation
2. Performance Specification
3. Applications
4. Installation
5. Commissioning
6. Maintenance
7. Diagrams

The copyright and other intellectual property rights in this document, and in any model or article produced from it (and including any registered or unregistered design rights) are the property of Siemens Protection Devices Limited. No part of this document shall be reproduced or modified or stored in another form, in any data retrieval system, without the permission of Siemens Protection Devices Limited, nor shall any model or article be reproduced from this document unless Siemens Protection Devices Limited consent.

While the information and guidance given in this document is believed to be correct, no liability shall be accepted for any loss or damage caused by any error or omission, whether such error or omission is the result of negligence or any other cause. Any and all such liability is disclaimed.

7PG26 DAD

High Impedance Relays

Document Release History

This document is issue 02/2010. The list of revisions up to and including this issue is:

Pre release

02/2010	Document reformat due to rebrand

Software Revision History

--	--	--

The copyright and other intellectual property rights in this document, and in any model or article produced from it (and including any registered or unregistered design rights) are the property of Siemens Protection Devices Limited. No part of this document shall be reproduced or modified or stored in another form, in any data retrieval system, without the permission of Siemens Protection Devices Limited, nor shall any model or article be reproduced from this document unless Siemens Protection Devices Limited consent.

While the information and guidance given in this document is believed to be correct, no liability shall be accepted for any loss or damage caused by any error or omission, whether such error or omission is the result of negligence or any other cause. Any and all such liability is disclaimed.

Contents

Contents	2
1. INTRODUCTION	3
2. DESCRIPTION OF FEATURES	3
3. CURRENT TRANSFORMERS	3
4. SELECTABLE SETTINGS	3
4.1. Current Settings	3
4.2. Alarm Setting.....	3
4.3. Time Delay Setting.....	3
4.4. Relay Reset.....	3
4.5. Selection of Latched/Non-Latched Output Contacts	4

1. INTRODUCTION

The type DAD relay provides high speed, high impedance, 3 phase current differential protection with individual open circuit monitoring of the CT secondary circuits. The input filter characteristic rejects the d.c. offset transient and provides excellent harmonic rejection.

2. DESCRIPTION OF FEATURES

An advanced design input filter with a harmonic rejection circuit improves overall protection stability by rejecting the harmonics generated by the onset of CT saturation. CT inputs to the relay are connected to internally isolating CTs. Their secondary circuit develops a normalised voltage across a current setting resistor combination, voltage clipping provides protection for continuous or short term overloads. The voltage signal is then applied to a low pass filter which attenuates frequencies above the fundamental such that the relay will not operate on third or higher harmonics. This output is then rectified and applied to alarm and trip level detectors. Alarm and trip comparators operate when their input exceeds their individual reference voltage. They initiate the alarm timer, LED's and output relays. DAD relays are provided with four output relays each with two contacts, three of the relays, those normally associated with the alarm function, can be selected for latched / non-latched contact operation.

3. CURRENT TRANSFORMERS

For high impedance schemes it is necessary to establish characteristics of the CT in accordance with Class "X" to BS3938. For most applications the required knee point voltage will not be high and it will be found that the overall size of the CT will be smaller than that required for alternative current balance protection.

4. SELECTABLE SETTINGS

Settings are all made using Dual-in-Line (DIL) switches.

4.1. Current Settings

The sum of the values indicated by the switch positions is the percentage of the relay rating (i.e. $I_n = 1A$ or $5A$) at which the relay will operate.

4.2. Alarm Setting

The alarm setting is selected as a percentage of the main current setting and is based on a minimum value, to which percentage increments are added.

4.3. Time Delay Setting

The time delay, in seconds, is the sum of the values indicated by the switch positions.

4.4. Relay Reset

The relay reset is operated using the sliding lever mounted on the relay front cover. Operating the reset clears the latched data, resets the display and any operated relays, and also Lamp Tests the display LED's.

4.5. Selection of Latched/Non-Latched Output Contacts

The relay outputs used for alarm functions can be set as either latched or non-latched. This setting is made using a set of DIL switches located on the bottom of the withdrawable relay chassis. See Section 5, Figure 8 for details of this setting.

7PG26 DAD

High Impedance Relays

Document Release History

This document is issue 02/2010. The list of revisions up to and including this issue is:

Pre release

02/2010	Document reformat due to rebrand

Software Revision History

--	--	--

The copyright and other intellectual property rights in this document, and in any model or article produced from it (and including any registered or unregistered design rights) are the property of Siemens Protection Devices Limited. No part of this document shall be reproduced or modified or stored in another form, in any data retrieval system, without the permission of Siemens Protection Devices Limited, nor shall any model or article be reproduced from this document unless Siemens Protection Devices Limited consent.

While the information and guidance given in this document is believed to be correct, no liability shall be accepted for any loss or damage caused by any error or omission, whether such error or omission is the result of negligence or any other cause. Any and all such liability is disclaimed.

Contents

1.	GENERAL	3
2.	CHARACTERISTIC ENERGIZING QUANTITY	3
3.	AUXILIARY ENERGIZING QUANTITY	3
4.	CHARACTERISTICS	3
4.1.	Input Settings	3
4.2.	Operating Times	3
5.	ACCURACY REFERENCE CONDITIONS	3
6.	ACCURACY	4
7.	ACCURACY GENERAL	4
8.	ACCURACY INFLUENCING FACTORS	4
9.	THERMAL WITHSTAND	4
10.	HARMONIC REJECTION	5
11.	BURDENS	5
11.1.	AC Burden	5
11.2.	DC Burden	5
12.	OUTPUT CONTACTS	5
12.1.	Contacts	5
12.2.	Indication	6
13.	ENVIRONMENTAL WITHSTAND	6

1. GENERAL

Performance Data to IEC 255-3

2. CHARACTERISTIC ENERGIZING QUANTITY

AC Current In	1A or 5A
Frequency	50/60Hz
No. of Poles	3

3. AUXILIARY ENERGIZING QUANTITY

DC Power Supply	
Nominal	Operating Range
Vaux 24, 30, 48V	18V to 60V dc
Vaux 110, 220, 250V*	88V to 280V dc

* This variant will also operate from 110, 115, 120Vrms, 50/60Hz; full operating range 88V to 132V.

4. CHARACTERISTICS

4.1. Input Settings

Setting Current	0.5% to 96% of In in
Is	0.5% steps
Open Circuit CT	50Hz 10% to 40% in
Alarm Setting	/60Hz 10% of Is steps
Ia	

4.2. Operating Times

Delay (Alarm)	0.25s to 63.75s in 0.25s
Output	steps

Instantaneous (Trip) Output (X/R up to 100)

Multiple of Relay Setting	Typical Operating Time
2 x Is	21ms
3 x Is	14ms
5 x Is	12ms

5. ACCURACY REFERENCE CONDITIONS

General	IEC 255-3
Trip Setting	Any setting
Alarm Setting	Any setting
Overcurrent Input	3 x Is
DTL Time	21.25s
Frequency	50/60Hz
Ambient	20°C
Temperature	

6. ACCURACY

Operating Current (Starter)	100% \pm 5% of setting
Reset	\geq 95% of operating current
Instantaneous Operate Time	+5ms, -10ms of declared operating time
Delay Operate Time	\pm 1% or \pm 10ms
Repeatability	\pm 1%

7. ACCURACY GENERAL

DC Transient Overreach	\leq -15%
Disengaging Time	\leq 55ms
Alarm Overshoot	at 10% of I_s δ 80ms at 40% of I_s δ 40ms

8. ACCURACY INFLUENCING FACTORS

Temperature

Ambient Range	-25°C to +55°C
Setting Variation	\pm 1%

Frequency

Range	47Hz to 51Hz 57Hz to 61Hz
Setting Variation	\pm 5%
Operating Time Variation	\pm 0.5%

Auxiliary DC Supply - IEC 255-11

Allowable superimposed ac component	\leq 12% of dc voltage
Allowable breaks / dips in supply (collapse to zero from nominal voltage)	\leq 20ms

9. THERMAL WITHSTAND

Continuous and Limited Period Overload

2 x I_n	Continuous
3 x I_n	for 20 minutes
3.5 x I_n	for 10 minutes
4 x I_n	for 5 minutes
5 x I_n	for 3 minutes
6 x I_n	for 2 minutes

Short Term Overload

5A	350A for 1 sec 600A for 1 cycle
1A	65A for 1 sec 120A for 1 cycle

10. HARMONIC REJECTION

The relay will not operate on third or higher harmonics.

2nd harmonic rejection	2: 1 minimum
3rd harmonic rejection	50Hz, 40: I minimum 60Hz, 20: I minimum

11. BURDENS

11.1. AC Burden

Burdens expressed in volts.

1A rating, $V_s = 0.120 + 0.78 \times I_s$

5A rating, $V_s = 0.025 + 0.08 \times I_s$

11.2. DC Burden

	18V to 60V	88V to 280V
Quiescent	0.25W	0.65W
Short Term	5W	8W

12. OUTPUT CONTACTS

12.1. Contacts

Carry Continuously 5A ac or dc

Make and Carry

(limit L/Rs 40ms and V δ 300 volts)

for 0.5s 20A ac or dc

for 0.2s 30A ac or dc

Break

(limit δ 5A or δ 300V)

ac resistive	1250VA
ac inductive	250VA @ PF δ 0.4
dc resistive	50W
dc inductive	30W @ L/R = 40ms 50W @ L/R = 10ms

Minimum number of operations 1000 at maximum load

Minimum recommended load 0.5W, limits 10mA or 5V

Output Relay	RL1	RL2	RL3	RL4
Function	Trip	'A' Alarm	'B' Alarm	'C' Alarm
Contacts	2 NO	2 NO	2 NO	2 NO
Operation	Inst	DTL	DTL	DTL
Latched	No	Select*	Select*	Select*

*See section 5, figure 8, for RL2-RL4 latching settings.

Normally open contacts are wired via case trip isolation contacts.

12.2. Indication

Two red LED's per phase are provided for TRIP and ALARM.

The alarm LED is illuminated when the alarm is exceeded and is latched on completion of the set time delay. Prior to the expiry of the time delay it resets when the input falls below the alarm setting.

Indications are retained in memory during breaks in the auxiliary supply and re-established when the supply is restored. Latched output contacts and indications are both reset from the case reset push. The reset action also tests all the LED's by momentarily illuminating them.

13. ENVIRONMENTAL WITHSTAND

Temperature - IEC 68-2-1/2

Operating range	-10°C to +55°C
Storage range	-25°C to +70°C

Humidity- IEC 68-2-3

Operational test	56 days at 40°C and 95% RH
------------------	----------------------------

Transient Overvoltage - IEC 255-5

Between all terminals and earth or between any two terminals without damage or flashover	5kV 1.2/50µs, 0.5J
--	--------------------

Insulation - IEC 255-5

Between any terminal and earth	2.0kV rms for 1 min
Between independent circuits	2.0kV rms for 1 min
Across normally open contacts	1.0kV rms for 1 min

High Frequency Disturbance - IEC 255-22-1 Class III

	Variation
2.5kV Common (Longitudinal) Mode	≤ 5%
1.0 kV Series (Transverse) Mode	≤ 1%

Electrostatic Discharge - IEC 255-22-2 Class III

8kV Contact Discharge	no maloperation
-----------------------	-----------------

Radio Frequency Interferences - IEC 255-22-3 Class III

	Variation
20MHz to 1000MHz, 10V/m	≤ 5%

Fast Transient - IEC 255-22-4 Class IV

	Variation
4 kV 5/50ns	≤ 5%

Vibration (Sinusoidal) - IEC 255-21-1

Vibration response	0.5gn	Variation	≤ 5%
Vibration endurance	2gn		no maloperation

Shock and Bump - IEC 255-21-2 Class I

Shock response	5gn 11ms	Variation	≤ 5%
Shock withstand	15gn 11ms		≤ 5%
Bump test	10gn 16ms		≤ 5%

Seismic - IEC 255-21-3 Class I

Seismic response	1gn	Variation	≤ 5%
------------------	-----	-----------	------

Mechanical Classification

Durability	In excess of 10 ⁶ operations
------------	---

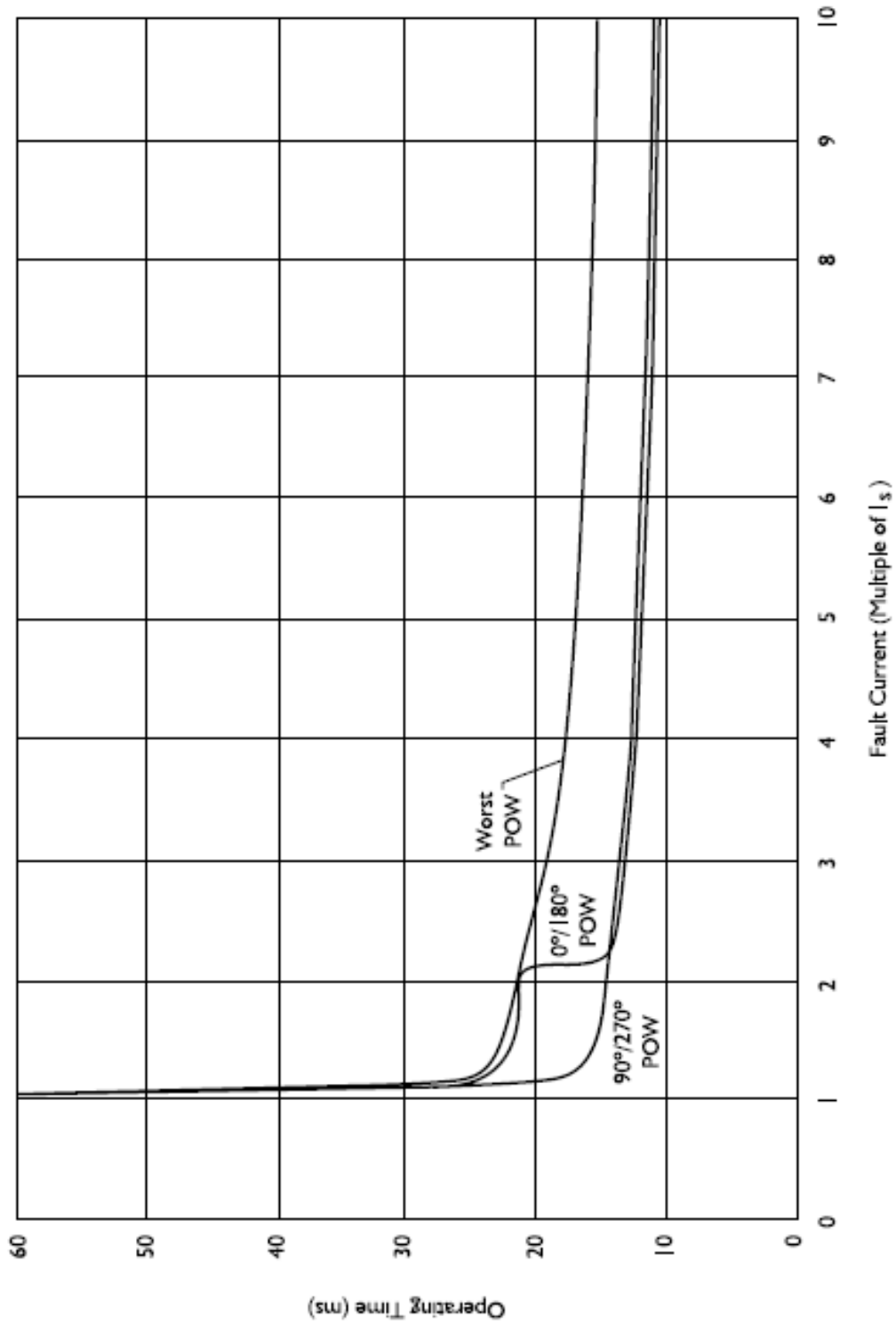

Figure 1 Trip Characteristic (X/R = 100)

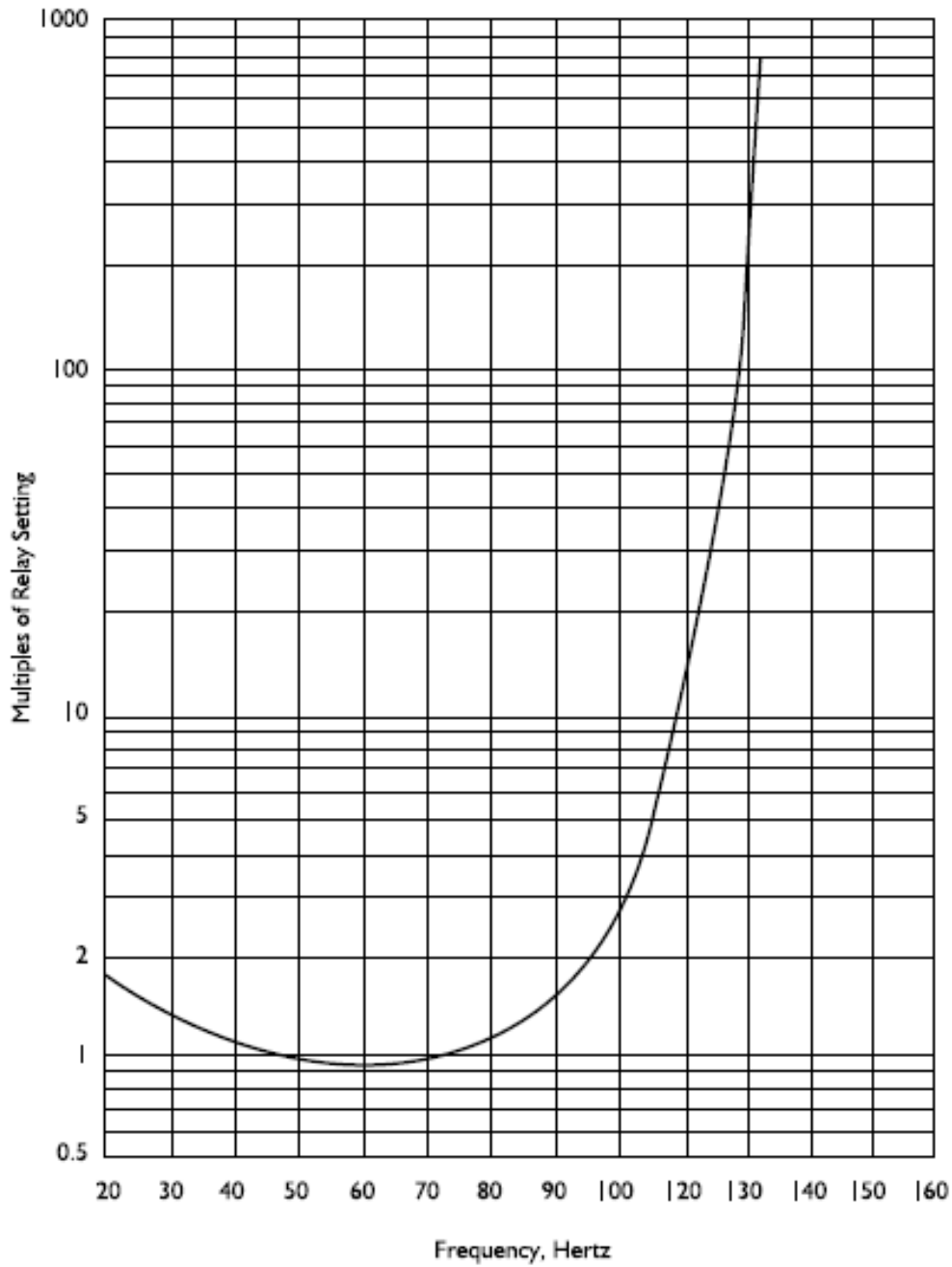

Figure 2 Harmonic Rejection Characteristic

7PG26 DAD

High Impedance Relays

Document Release History

This document is issue 02/2010. The list of revisions up to and including this issue is:

Pre release

02/2010	Document reformat due to rebrand

Software Revision History

--	--	--

The copyright and other intellectual property rights in this document, and in any model or article produced from it (and including any registered or unregistered design rights) are the property of Siemens Protection Devices Limited. No part of this document shall be reproduced or modified or stored in another form, in any data retrieval system, without the permission of Siemens Protection Devices Limited, nor shall any model or article be reproduced from this document unless Siemens Protection Devices Limited consent.

While the information and guidance given in this document is believed to be correct, no liability shall be accepted for any loss or damage caused by any error or omission, whether such error or omission is the result of negligence or any other cause. Any and all such liability is disclaimed.

Contents

1. INTRODUCTION	3
2. THEORY OF HIGH IMPEDANCE CURRENT BALANCE PROTECTICE SCHEMES AND THEIR APPLICATION	3
2.1 Determination of Stability	3
2.2 Current Transformer Requirements	4
2.3 Overvoltage Protection.....	4
2.4 Fault Setting.....	4
2.4.1 To give required current setting.....	5

1. INTRODUCTION

The relay can be used for high impedance busbar zone protection and circulating current protection of auto transformers, motors, and generators, and restricted earth fault protection. A simplified scheme is shown in figure 1.

Transient stability under through fault conditions is a problem with many forms of differential protection due to variations in CT magnetizing characteristics. As saturation is approached, the CT output current waveforms become increasingly distorted with high percentage of 3rd and other higher odd harmonics. These problems can be overcome by either using biased differential protection, or more elegantly by the use of high impedance schemes. In the latter case the relay settings are calculated with known stability margins. Intermediate conditions, where a CT is only partially saturated, increases the stability margin. This approach enables schemes to be engineered using CTs with relatively low knee point voltages.

The DAD relay also incorporates supervision of CT secondary circuits. This supervision provides a desirable safety feature particularly where the CTs are switched for different busbar arrangements. When carrying load current an open circuit CT will cause unbalance in any current balance group. As this can cause instability it is normal practice to use a sensitive relay to detect this condition. In addition to initiating an alarm after a time delay, zone switched relays, when they are required, can be energized to switch out the affected zone. This integration of protection, CT supervision and associated timers considerably simplifies system design and secondary wiring.

High impedance busbar protection is recommended for all switchgear applications where faults must be cleared in the shortest possible time. High impedance schemes can provide lower fault settings and better through fault stability than most other schemes.

The stability of a current balance scheme using a high impedance relay circuit depends upon the relay voltage setting being greater than the maximum voltage which can appear across the relay under a given fault condition. A setting resistor or resistors, and non linear resistor, per phase, complete the scheme and are mounted externally to the relay. The resistor value is determined by the voltage level required for stability and the value of relay current calculated to provide the required primary fault setting. Non linear resistors protect the CTs and relay from the excessively high voltages which may occur e.g. for high values of in-zone fault current.

2. THEORY OF HIGH IMPEDANCE CURRENT BALANCE PROTECTICE SCHEMES AND THEIR APPLICATION

2.1 Determination of Stability

The stability of a current balance scheme using a high impedance relay circuit is based on the fact that for a given through fault condition, the maximum voltage that can occur across the relay circuit is determined by means of a simple calculation. If the setting voltage of the relay is made equal to or greater than this voltage, then the protection will be stable.

In calculating the required setting voltage of the relay it is assumed that one current transformer is fully saturated and that the remaining CTs maintain their ratio. In this condition, the excitation impedance of the saturated CT is negligible and the resistance of the secondary winding, together with leads connecting the CT to the relay terminals, constitute the only burden in parallel with the relay as shown in figure 2.

Thus the voltage across the relay is given by:

$$V = I \times (X1 + Y1) \text{ for CT1 saturated}$$

$$V = I \times (X2 \times Y2) \text{ for CT2 saturated}$$

X1 and X2	= the secondary winding resistances of the CTs
Y1 and Y2	= the value of the pilot loop resistance between the relative CT and the relay circuit terminals
I	= the CT secondary current corresponding to the maximum steady state through fault current of the protected equipment
V	= the maximum voltage that can occur across the relay circuit under through fault conditions

For stability, the voltage setting, V_s , of the relay must be made equal to or exceed, the highest value of V calculated above.

Experience and extensive laboratory tests have proved that if this method of estimating the relay setting voltage is adopted, the stability of the protection will be much greater than the value of I used in the calculation. This is because a CT is normally not continuously saturated and consequently any voltage generated by this CT will reduce the voltage appearing across the relay circuit.

The DAD is a low burden, current operated relay and the stability voltage setting is achieved by employing a series resistor of appropriate ohmic value (e.g. depending on the current setting chosen) and power dissipation rating.

2.2 Current Transformer Requirements

For high impedance schemes it is necessary to establish characteristics of the CT in accordance with Class 'X' to BS 3938 and that where the CTs are specifically designed for this protection their overall size may be smaller than that required for an alternative current balance protection. The basic requirements are:

All CTs should, if possible have identical turns ratios.

The knee point voltage of each CT, should be at least $2 \times V_s$. The knee point voltage is expressed as the voltage applied to the secondary circuit with the primary open circuit which when increased by 10% causes the magnetizing current to increase by 50%.

CTs should be of the low leakage reactance type. Most modern CTs are of this type and there is no difficulty in meeting this requirement. A low leakage reactance CT has a joint less ring type core, the secondary winding evenly distributed along the whole length of the magnetic circuit and the primary conductor passes through the appropriate centre of the core.

2.3 Overvoltage Protection

The maximum primary fault current in the protected zone will cause high voltage spikes across the relay at instants of zero flux since a practical CT core enters saturation on each half-cycle for voltages of this magnitude. Thus it is necessary to suppress the voltage with a non linear resistor in a shunt connection which will pass the excess current as the voltage rises. The type of non linear resistor required is chosen by its thermal ring.

2.4 Fault Setting

The fault setting of a current balance protection using a high impedance relay circuit can be calculated in the following manner.

$$\text{Primary fault setting} = N (I + I_1 + I_2 + I_3 + I_{sh})$$

I	= the relay operating current
I_1, I_2, I_3	= the excitation currents of the CTs at the relay setting voltage
N	= the CT ratio
I_{sh}	= other shunt circuits where provided e.g. non linear resistor etc.

The fault setting of the protective scheme depends upon the protected equipment and the type of system earthing. For a solidly earthed power transformer a fault setting of 10 to 60% of the rated current of the protected winding is recommended. If the power transformer is earthed through a resistor rated to pass a earth fault current of 100% of more the rated current of the protected winding, a fault setting of 10 to 25% of the rated current of the earthed resistor is recommended.

In the case of feeders terminating in a power transformer, it may be necessary to increase the basic fault setting to ensure that the capacitance currents of the feeder do not impair the stability of the protection. For stability during an external fault on the system to which the feeder is connected, the fault setting should preferably be greater than three times the residual capacitance current of the feeder. The maximum residual capacitance current is equal to the capacitance current to earth per phase at normal voltage in the case of a feeder in a solidly earthed system. Higher fault settings can be obtained as described in the following section.

2.4.1 To give required current setting

The primary fault current setting required can usually be obtained by employing the appropriate DAD current settings. Alternatively, when the required fault setting is large, the correct result can be obtained by connecting a resistor in parallel with relay circuit, thereby effectively increasing the value of primary current setting. The DAD minimum current setting is 5mA and this is normally sufficient to achieve the most onerous requirement for sensitivity. However where a very high sensitivity is required the CT magnetisation current at the relay circuit operating voltage must be kept to a low value in order to reduce the primary operating current further.

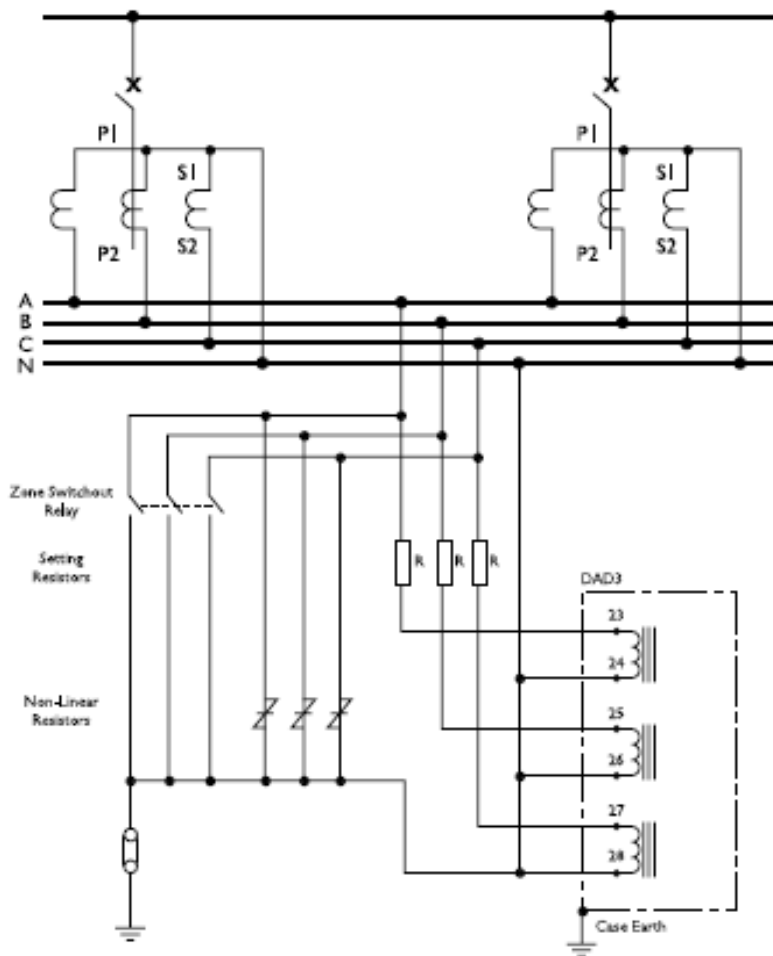

Figure 1 Simplified Typical A.C. Schematic Diagram for Bus Zone Protection

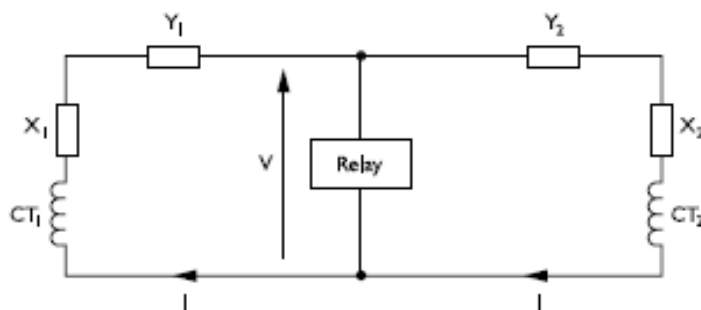

Figure 2 Basic Circulating Current Scheme

7PG26 DAD

High Impedance Relays

Document Release History

This document is issue 02/2010. The list of revisions up to and including this issue is:

Pre release

02/2010	Document reformat due to rebrand

Software Revision History

--	--	--

The copyright and other intellectual property rights in this document, and in any model or article produced from it (and including any registered or unregistered design rights) are the property of Siemens Protection Devices Limited. No part of this document shall be reproduced or modified or stored in another form, in any data retrieval system, without the permission of Siemens Protection Devices Limited, nor shall any model or article be reproduced from this document unless Siemens Protection Devices Limited consent.

While the information and guidance given in this document is believed to be correct, no liability shall be accepted for any loss or damage caused by any error or omission, whether such error or omission is the result of negligence or any other cause. Any and all such liability is disclaimed.

Contents

Contents..... 2
1. UNPACKING, STORAGE AND HANDLING 3
2. RECOMMENDED MOUNTING POSITION 3
3. RELAY DIMENSIONS..... 3

1. UNPACKING, STORAGE AND HANDLING

On receipt, remove the relay from the container in which it was received and inspect it for obvious damage. To prevent the possible ingress of dirt the sealed polythene bag should not be opened until the relay is to be used.

If damage has been sustained a claim should immediately be made against the carrier, also inform Reyrolle Protection and the nearest Reyrolle agent.

When not required for immediate use, the relay should be returned to its original carton and stored in a clean dry place.

2. RECOMMENDED MOUNTING POSITION

The relay should be mounted on the circuit breaker or panel to allow the operator the best access to the relay functions.

3. RELAY DIMENSIONS

The relay is supplied in a case range size 6.

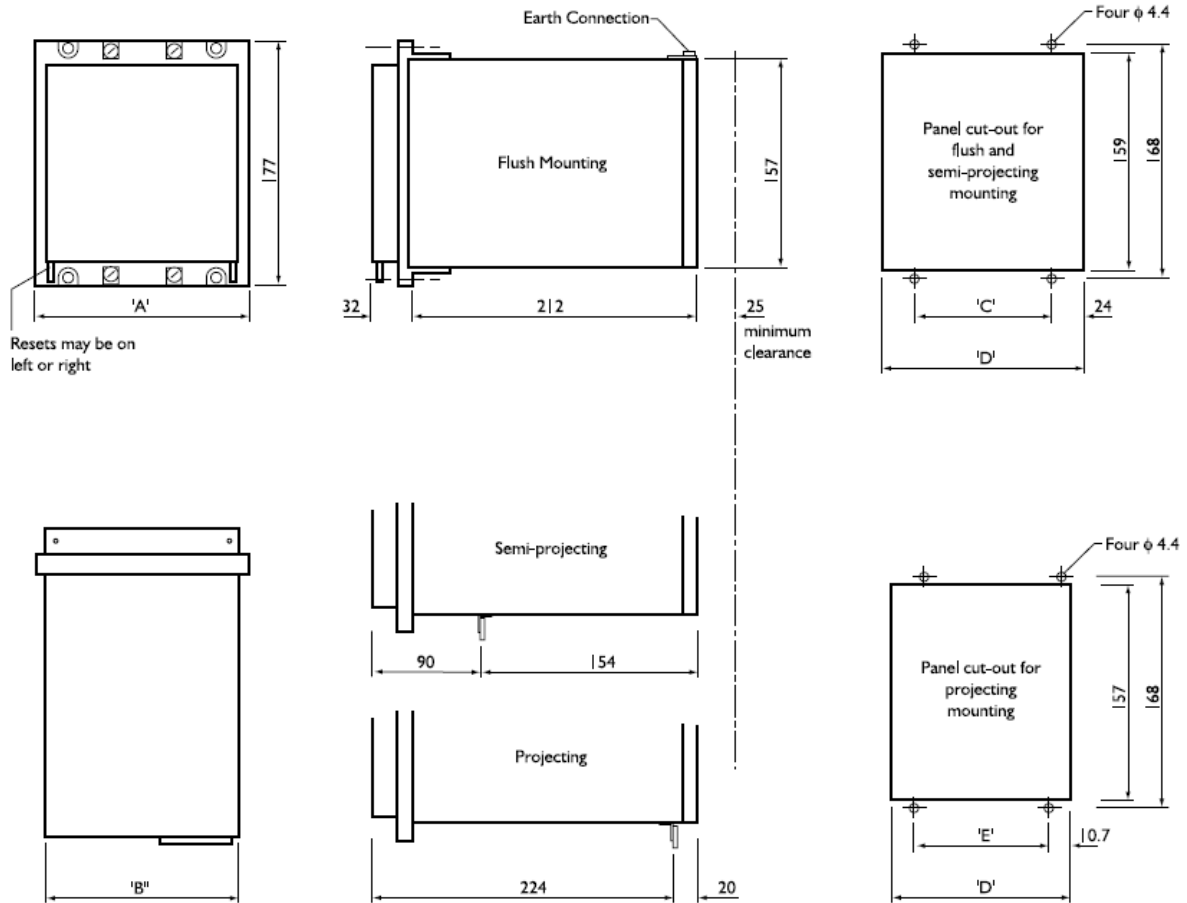

Dimensions					
Case	A	B	C	D	E
R6	155	149	103.6	151	129.5

Fig 1. Size 6 Case

7PG26 DAD

High Impedance Relays

Document Release History

This document is issue 02/2010. The list of revisions up to and including this issue is:

Pre release

02/2010	Document reformat due to rebrand

Software Revision History

--	--	--

The copyright and other intellectual property rights in this document, and in any model or article produced from it (and including any registered or unregistered design rights) are the property of Siemens Protection Devices Limited. No part of this document shall be reproduced or modified or stored in another form, in any data retrieval system, without the permission of Siemens Protection Devices Limited, nor shall any model or article be reproduced from this document unless Siemens Protection Devices Limited consent.

While the information and guidance given in this document is believed to be correct, no liability shall be accepted for any loss or damage caused by any error or omission, whether such error or omission is the result of negligence or any other cause. Any and all such liability is disclaimed.

Contents

Contents	2
1. REQUIRED TEST EQUIPMENT.....	3
2. PRECAUTIONS.....	3
3. PROGRAMME OF TESTS.....	3
4. CHECK OF CT SECONDARY WIRING AND PILOT RESISTANCE	3
5. INSULATION RESISTANCE TESTS.....	3
6. SECONDARY INJECTION TESTS.....	4
6.1. Checking the relay voltage and current settings.....	4
6.2. Checking the relay operating time.....	4
7. PRIMARY INJECTION TESTS	4
7.1. CT ratio and polarity tests	4
7.2 Choice of standard circuit.....	4
7.3 Test of ratios of the standard circuit CT's	5
7.4. Test of polarities of the standard CT's.....	5
7.5. Test of ratios and polarities of CTs of the remaining circuits.....	6
7.6. Test of overlap of busbar section and busbar coupler current transformers.....	6
7.7. Test of fault setting by primary injection	6
7.8. CT supervision alarm setting.....	7
8. PUTTING INTO SERVICE	7

1. REQUIRED TEST EQUIPMENT

_ AC voltage source rated for 5 x In, i.e. 1A relay, 5A source, 5A relay, 25A source.

NOTE: The test source must be capable of accurately supplying current down to 0.5% of the relay rating and also the setting voltage.

- _ Time interval meter 0-100s.
- _ 1 Voltmeter.
- _ Up to 3 Ammeters.
- _ 1 to 1000V insulation resistance test set.
- _ A single phase primary injection test set 500A at 5kVA.
- _ Suitable test leads.

2. PRECAUTIONS

The commissioning and future maintenance of this equipment should only be carried out by skilled personnel trained in protective relay operation and capable of observing all the necessary safety precautions and regulations appropriate to this equipment and also the associated primary plant. Equipment should be isolated from the auxiliary supplies and the circuit breaker trip circuit prior to commencing any work on an installed product. Do not open circuit the secondary winding of a current transformer while current is flowing in the primary. This can result in high voltages which may be dangerous to personnel and may damage the secondary wiring.

3. PROGRAMME OF TESTS

Apply tests in the order given below:

- _ Selection of latch/non-latched output contacts, (see figure 8)
- _ Check of CT secondary wiring resistance
- _ Insulation resistance tests
- _ Secondary injection tests
- _ Primary injection tests
- _ Put into service

4. CHECK OF CT SECONDARY WIRING AND PILOT RESISTANCE

Before commencing to inspect the wiring and measuring pilot resistance take the following precautions:

- _ Isolate the auxiliary supplies.
- _ Remove the trip and intertrip links.
- _ Earth links open.
- _ Changeover links of the circuits under test removed.

Check that the relay wiring is complete and that all terminal connections comply with the relevant scheme diagrams. Connect an ohmmeter across the short circuiting position of each changeover link in turn, to measure the resistance of the CT secondary winding and pilot leads of each phase. The setting report for the protection should state the maximum permissible value of the d.c. resistance for the CT secondary winding and the pilot resistance. The sum of these two values should be compared with values measured above to ensure it is not exceeded.

Record the results in Table 1.

5. INSULATION RESISTANCE TESTS

Measure the insulation resistance between each section of the wiring and the other sections connected together and to earth.

The sections comprise:

- _ CT secondary wiring connected to the a.c. input circuits.
- _ D.C. wiring connected to the relay power supply.
- _ D.C. wiring connected to output contacts.

Record the results in Table 2.

Insulation resistance values which may be considered satisfactory must depend upon the amount of wiring involved. Generally, where a considerable amount of multicore wiring is included, a reading of $2M\Omega$ or $3M\Omega$ is reasonable. For short lengths of wiring on a panel, higher readings should be expected. A reading of $1M\Omega$ or less should not normally be considered satisfactory.

6. SECONDARY INJECTION TESTS

Isolate the d.c. supplies for alarm and tripping from the relay and remove the trip and intertrip links. Ensure the relay is powered from a suitable d.c. supply:

- _ 18V to 60V d.c. or 88V to 280V d.c.

6.1. Checking the relay voltage and current settings

The CT alarm time delay should be at a minimum. Check that the required setting is applied to each pole of the relay. The CT alarm setting is a percentage of the applied setting. The voltage setting is dependant upon the value of the setting resistor. Fig. 2 shows the test circuit. Inject into each phase in turn and slowly increase the voltage, note the level of voltage and current that causes the CT alarm to operate by either observing the LED indication or monitor the operation of the alarm output contacts.

NOTE: Alarm contacts are selected latched or un-latched. When latched is selected the contacts are reset from the operation of the relay reset lever. Continue increasing the voltage until the protection operates, this can be determined by the Protection operated LED illuminating and by operation of the trip output contacts.

Record the results in Table 3.

6.2. Checking the relay operating time

Inject a current equal to three times the relay setting and record the operating time of the trip output contacts. Set the time delay for the CT alarms and inject a level of current equal to three times the relay setting and record the operating time of the alarm output contacts.

Record the results in Table 4.

7. PRIMARY INJECTION TESTS

If the CT's associated with the protection are located in power transformer bushings or gas filled circuit breakers it may not be possible to apply test connections to the busbar under test.

7.1. CT ratio and polarity tests

Since the protective system is of the current balance type it is important that the CT's should have the same ratio and be connected together with the correct polarities. To check the ratio and polarities, choose one circuit as standard, test its CT's then check those of the remaining circuits against them as described in the following sections.

7.2 Choice of standard circuit

If possible, choose a standard circuit that:

- _ Will be readily available throughout the tests.
- _ Will present no undue difficulty from the point of view of primary injection.
- _ Is near the centre of the switchboard, in order to avoid long testing connections.

In a single busbar installation having more than one discriminating zone, select a standard circuit for each zone. In a duplicate busbar installation in which the CT's of two or more main busbar zones may be connected in the same reserve busbar zone, check the CT's of those zones against the same standard, or against CT's that have been checked against the standard. When in doubt, study the layout of the busbars and circuits and arrange the tests so as to prove that the balance can be maintained for all possible operating arrangements of the circuit breakers and isolators.

7.3 Test of ratios of the standard circuit CT's

Test each CT of the standard circuit as described below, using the connections shown in fig. 3.

See that the links, fuses, and isolating switches are as follows:

- _ Trip and intertrip links removed.
- _ Supply links and fuse links removed.
- _ Earth links open.
- _ Trip supply isolating links/switches open.
- _ Changeover links of the phase under test of the standard circuit and the test circuit removed and ammeters inserted.
- _ All other changeover test links in the short circuiting position.
- _ Relay test link associated with the CT under test removed and an ammeter inserted.
- _ All other relay test links in the normal position.

Short circuit the relay and setting resistor associated with the CT being tested; pass a current through the primary of the CT to give about 0.5A in the secondary circuit, measure the secondary current across the normal position of the changeover test link and at the relay test link. The current at both links should be equal to:
 Primary injected current / CT ratio

Record the results in Table 5.

Transfer the ammeter from the relay test block to the short circuiting position of the changeover link. If the secondary current is the same as before, for the same value of primary current, it verifies that the link will correctly short circuit the CT.

Check the labelling of the changeover links and relay test links. In duplicate busbar schemes, test in both the main and reserve busbar zones, i.e. with the busbar selector switch in each position, to check all the wiring.

7.4. Test of polarities of the standard CT's

Test the relative polarities of the CT's of the standard circuit in pairs as described below, using the connections shown in fig. 4.

See that the links and fuses are as follows:

- _ Trip and intertrip links removed.
- _ Supply links and fuse links removed.
- _ Earth links open.
- _ Changeover links of the phase under test of the standard circuit and the test circuit removed and ammeters inserted.
- _ All other changeover test links in the short circuiting position
- _ Relay neutral test link removed and an ammeter inserted.
- _ All other relay test links in the normal position.

Short circuit the relays and setting resistors at the relay test links as shown in fig. 4; pass the same value of current as in the ratio test through the primaries of the two CT's, so as to simulate a phase to phase fault, and measure the secondary current at the relay neutral link. In a scheme that has one 3 phase main relay per zone the current at both changeover links should be: Primary injected current / CT ratio and there should be no current at the neutral link. If the current at the neutral link is equal to the sum of the currents at the relay links, one of the CT's is reversed.

7.5. Test of ratios and polarities of CTs of the remaining circuits

Compare the ratio and polarity of each CT on the remaining circuits with the corresponding CT on the standard circuit as described below, using the connections shown in fig. 5. See that the links, fuses, and isolating switches are as follows:

- _ Trip and intertrip links removed.
- _ Supply links and fuse links removed.
- _ Earth links open.
- _ Trip supply isolating switches open.
- _ Changeover links of the phase under test of the standard circuit and the test circuit removed and ammeters inserted.
- _ All other changeover test links in the short circuiting position.
- _ Relay neutral test link removed and an ammeter inserted.
- _ All other relay test links in the normal position.

Short circuit the relays and setting resistors; pass the same value of current as in the tests of the standard circuit CT's through the primaries of the two CT's being compared, measure the secondary current at the changeover links of the standard and test circuits and at the relay neutral link. The current at each changeover link should be equal to: Primary injected current / CT ratio and there should be no current at the relay neutral link. If the current at the neutral link is equal to the sum of the currents at the two changeover links, the secondary connections of the CT under test are reversed. When the ratio and polarity of the CT under test have been proved correct, transfer the ammeter from the normal to the short circuiting position of the test circuit changeover link. If the ammeter reading is the same as before, for the same value of primary current, it verifies that the changeover link will correctly short circuit the CT. Check the labelling of the changeover links and relay test links. In duplicate busbar schemes, test in both the main busbar and reverse busbar zones, i.e. with the busbar selector switches in each position, to check all the wiring.

7.6. Test of overlap of busbar section and busbar coupler current transformers

The principle of overlapping the CT's of the busbar section and busbar coupler circuits is illustrated in fig. 6. The CT's shown on the right hand side of the circuit breaker are connected to zone I current balance group and those on the left hand side to zone 2 group. Test each phase in turn as described below, using the connections shown in fig. 6.

See that the links, fuses, and isolating switches are as follows:

- _ Trip and intertrip links removed.
- _ Supply links and fuse links removed.
- _ Earth links open.
- _ Trip supply isolating links/switches open.
- _ Changeover links of the busbar section or busbar coupler circuit under test in the normal position in both zones.
- _ All other changeover test links in the short circuiting position.
- _ Relay test links of the phase under test in both zones removed and ammeters inserted.
- _ All other relay test links in the normal position.

Energise the primary injection test equipment and see that the relay of the correct zone is energised.

7.7. Test of fault setting by primary injection

See that the links, fuses, and isolating switches are as follows:

- _ Trip and intertrip links removed.
- _ Supply links and fuse links removed.
- _ Earth links open.
- _ Trip supply isolating links/switches open.
- _ All other changeover links in the normal position.

- _ Relay test link associated with the CT energised in the test removed and an ammeter inserted.
- _ All other relay test links in the normal position.

Measure the phase fault and earth fault settings (for each phase) in each zone. Use the connections shown in fig. 7.

7.8. CT supervision alarm setting

The requirements for this test are identical with those described above and it will normally be possible to make the two tests at the same time.

Measure the settings in terms of the injected primary current.

Measure the secondary voltage and current at which operation occurs and record in Table 6.

8. PUTTING INTO SERVICE

To put the protective system into service proceed as follows:

- _ Put all changeover links, relay test links, and earth links in their normal position.
- _ Check all relays and flags are reset.
- _ Insert all trip supply links and fuses.
- _ Insert all trip and intertrip links.

	Resistance ($R_p + R_n + R_s$) Ohms	Resistance ($R_p' + R_n' + R_s'$) Ohms	Setting Report Max. Permissible Value Ohms		
Phase A					
Phase B					
Phase C					
Neutral					

Table 1 - Wiring Resistance

Wiring Section	Resistance Megaohms
CT Secondary Circuits	
DC Power Supply Wiring	
DC Wiring	

Table 2 - Wiring Insulation Resistance

	Alarm Setting	Measured Value	Relay Setting	Measured Value
Phase A				
Phase B				
Phase C				

Table 3 - Relay Fault Settings

	Alarm Timer Setting	Alarm Measured Time	Relay Opening Time
Phase A			
Phase B			
Phase C			

Table 4 - Relay Operating Times

	Primary Current Amps	Secondary Current Amps	Calculated Secondary Current Amps
Phase A			
Phase B			
Phase C			

Table 5 - Current Transformer Ratios

Circuit												
	A1 Amps	A2 Amps	V Volts	A1 Amps	A2 Amps	V Volts	A1 Amps	A2 Amps	V Volts	A1 Amps	A2 Amps	V Volts
Phase A												
Phase B												
Phase C												

Table 6 - Fault Settings

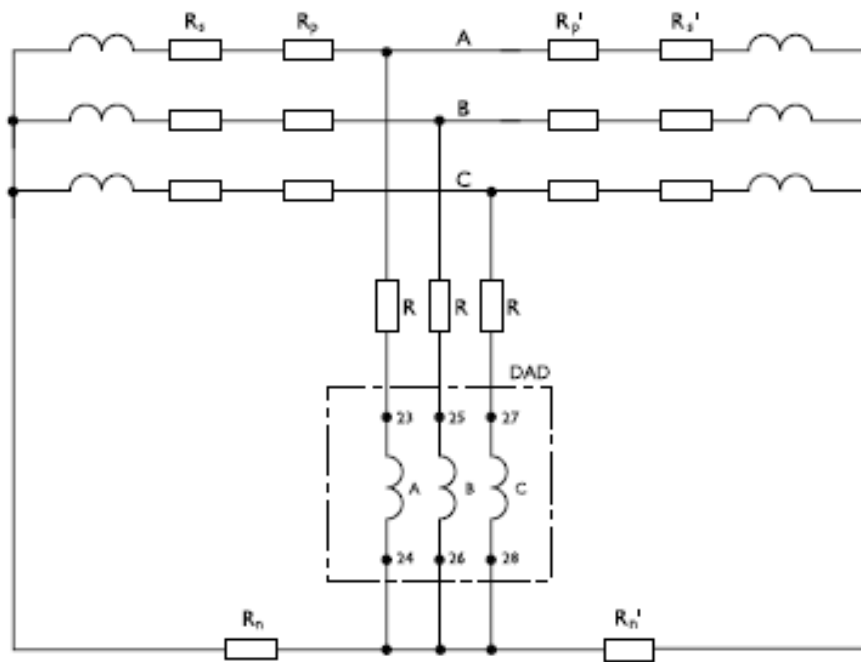

R_s & R_s' = Resistance of C.T. secondary of circuit 1 (R_s) and circuit 2 (R_s')
 R_p & R_p' = Resistance of phase wiring of circuit 1 (R_p) and circuit 2 (R_p')
 R_n & R_n' = Resistance of neutral wiring of circuit 1 (R_n) and circuit 2 (R_n')
 R = Stabilising resistance

Figure 1 Circuit Resistances

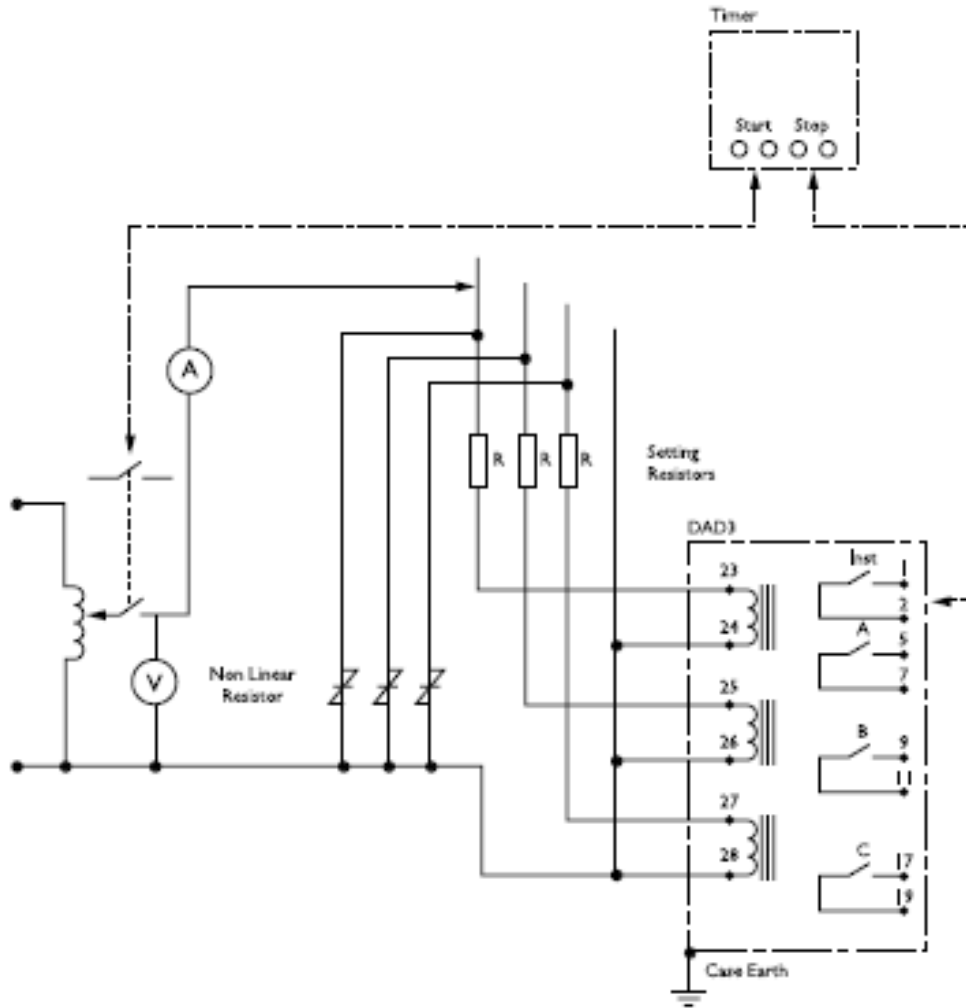

Figure 2 Checking Relay Current and Voltage Settings

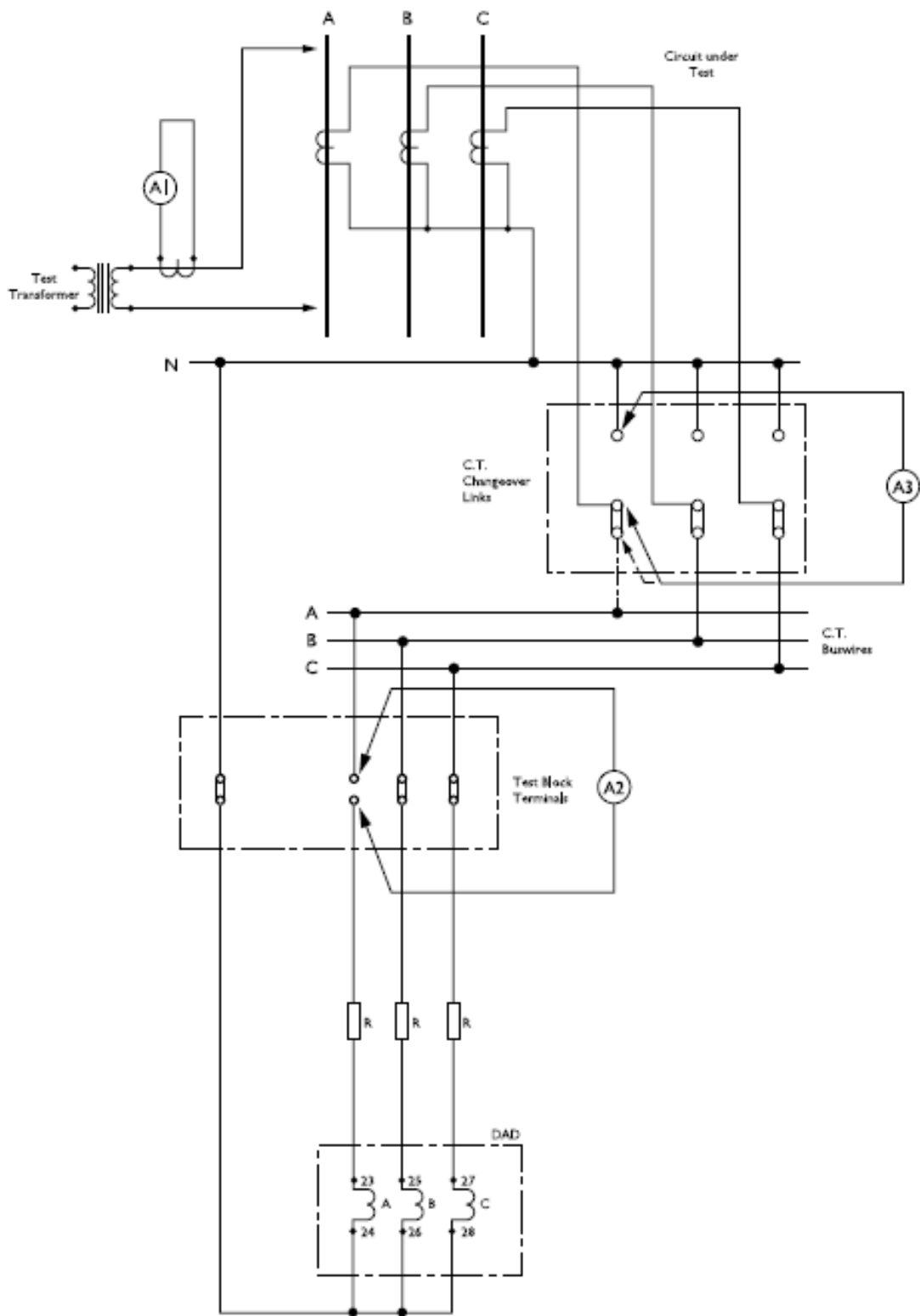

Figure 3 Connections for the Test of Current Transformers Ratios

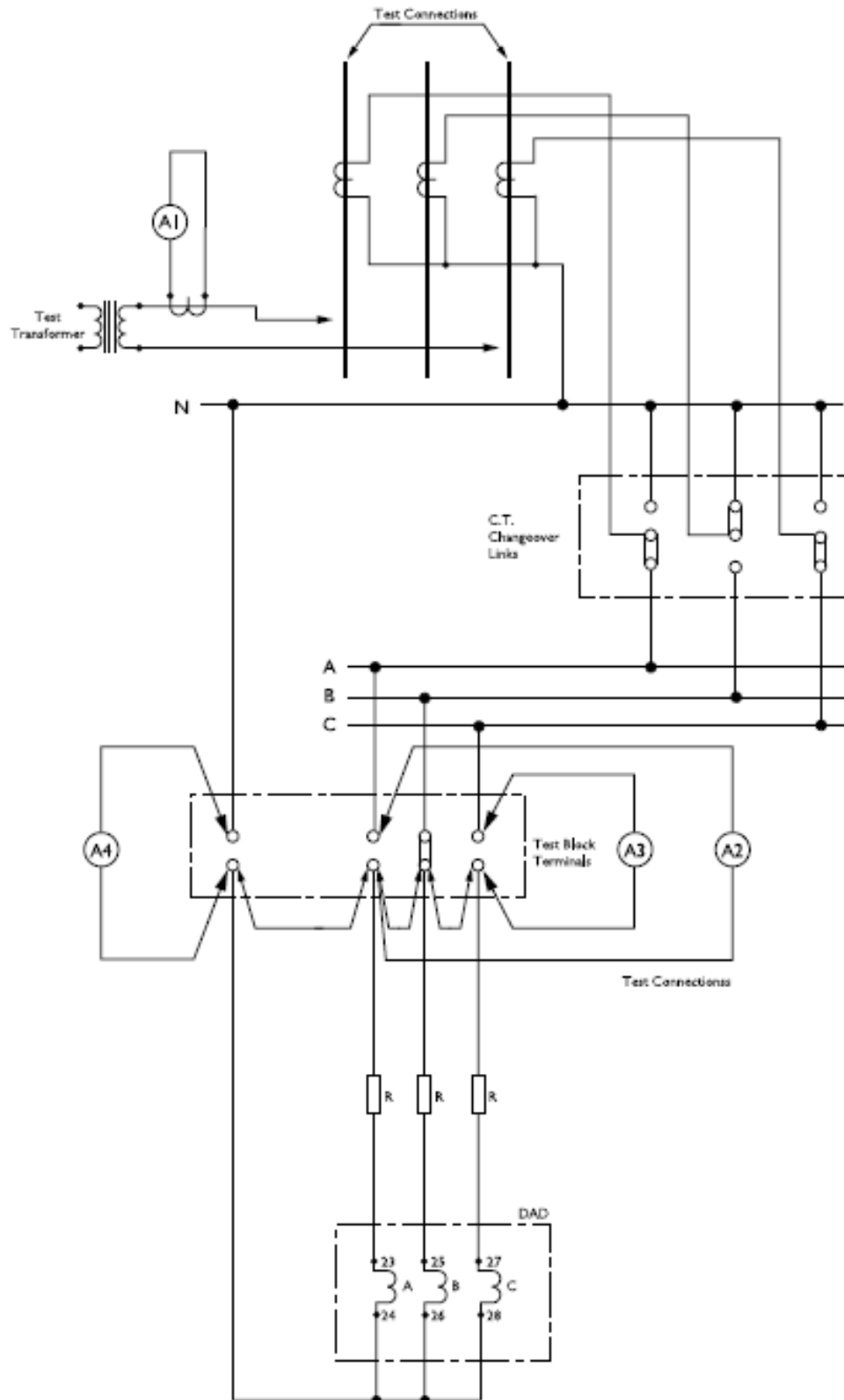

Figure 4 Connections for the Ratio Test of C.T.'s

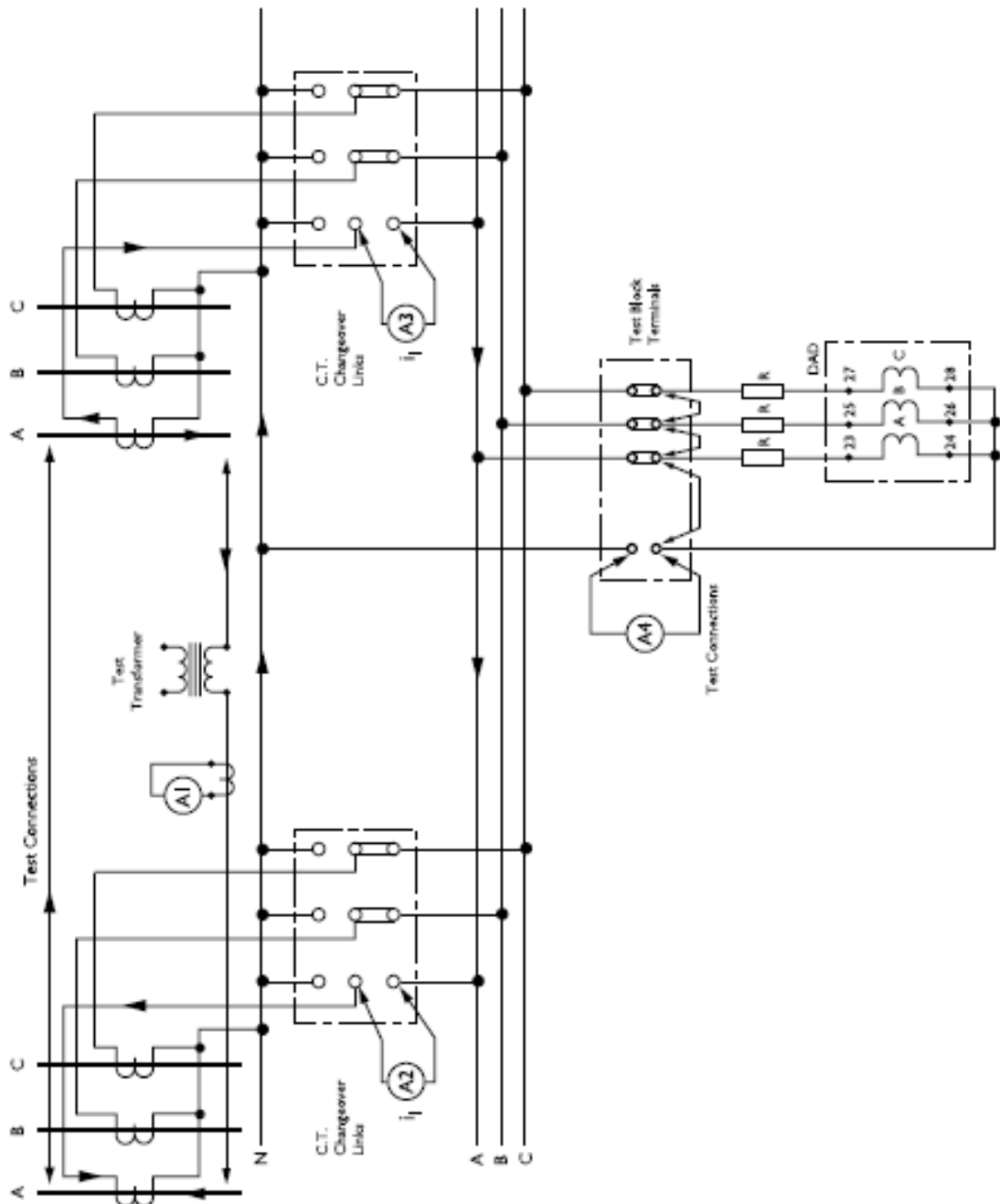

Figure 5 Connections for the Test of a C.T. against a Standard Circuit C.T.

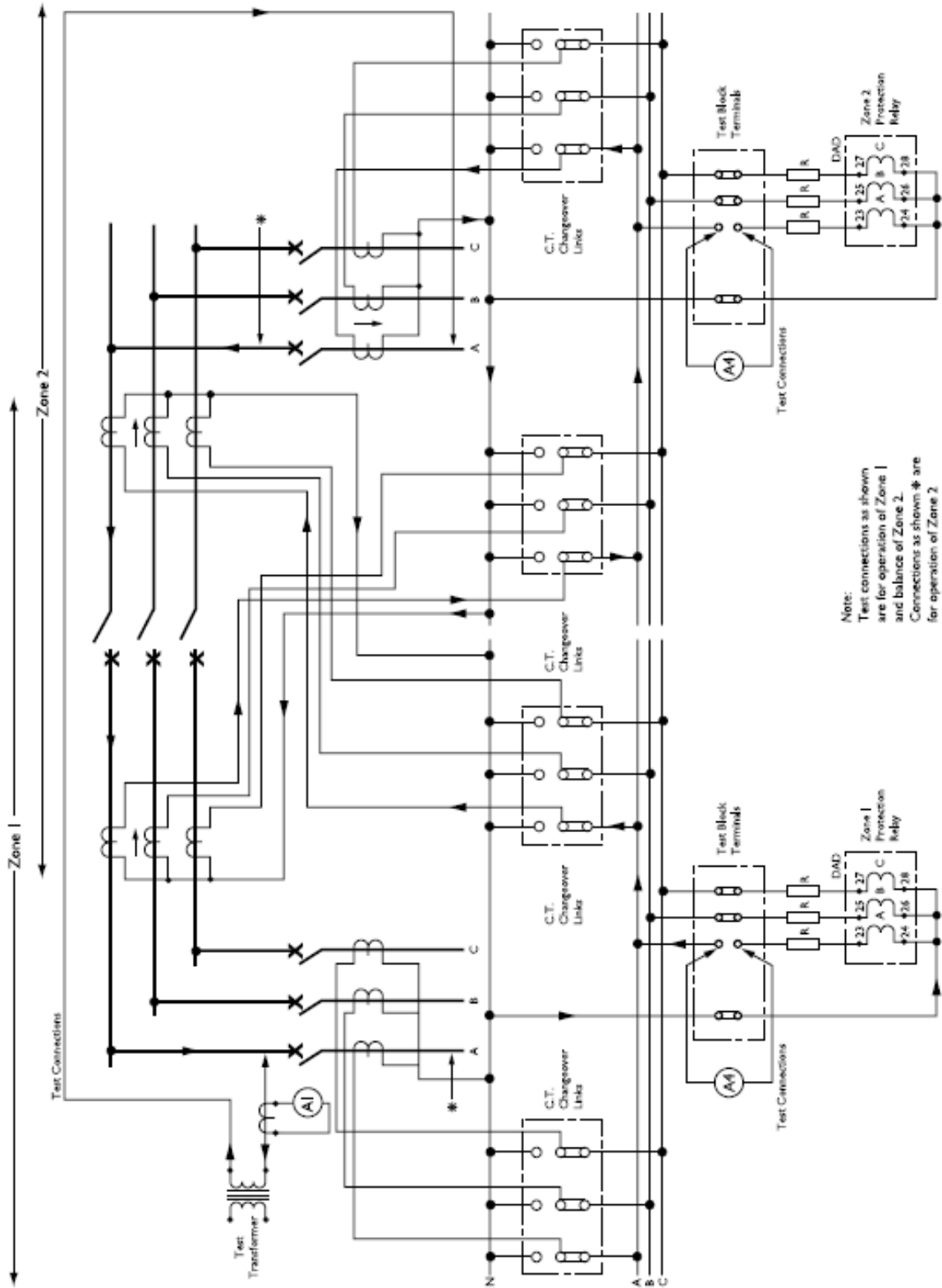

Figure 6 Connections for C.T. Test of Overlap by Primary Injection

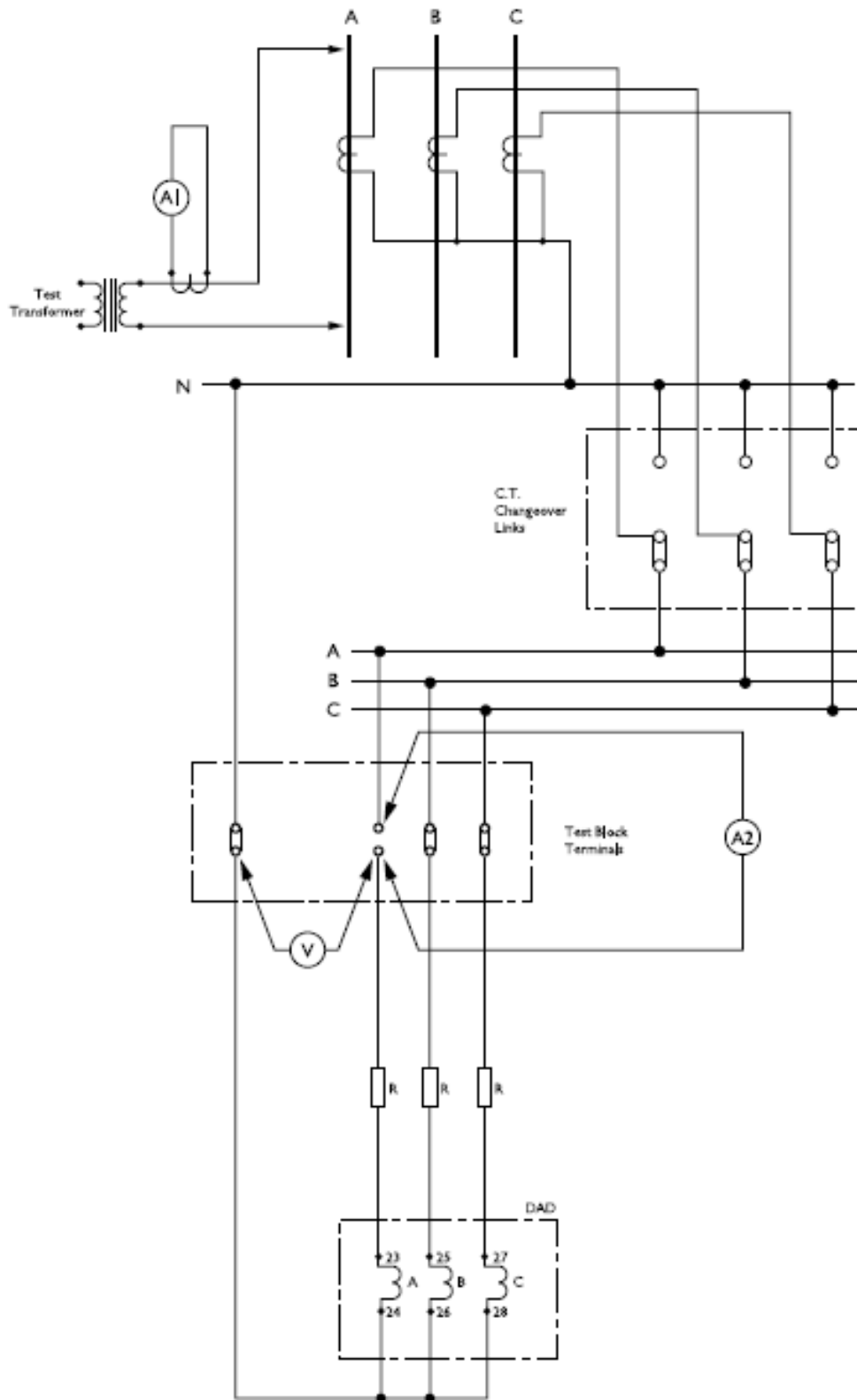
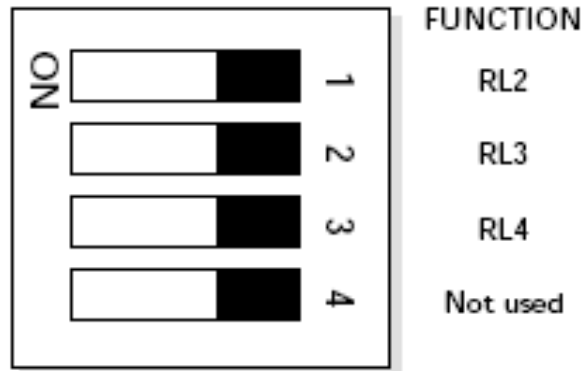

Figure 7 Test Circuit for the Determination of Fault Settings

The DIL switches shown are located on the bottom face of the withdrawable relay chassis. Function is as shown in the diagram



With the switches in the ON position, the relevant relay is latched

Figure 8. Selection of Latched/Non-Latched Output Contacts

7PG26 DAD

High Impedance Relays

Document Release History

This document is issue 02/2010. The list of revisions up to and including this issue is:

Pre release

02/2010	Document reformat due to rebrand

Software Revision History

--	--	--

The copyright and other intellectual property rights in this document, and in any model or article produced from it (and including any registered or unregistered design rights) are the property of Siemens Protection Devices Limited. No part of this document shall be reproduced or modified or stored in another form, in any data retrieval system, without the permission of Siemens Protection Devices Limited, nor shall any model or article be reproduced from this document unless Siemens Protection Devices Limited consent.

While the information and guidance given in this document is believed to be correct, no liability shall be accepted for any loss or damage caused by any error or omission, whether such error or omission is the result of negligence or any other cause. Any and all such liability is disclaimed.

1 Maintenance Instructions

The Argus 7 is a maintenance free relay, with no user serviceable parts. During the life of the relay it should be checked for operation during the normal maintenance period for the site on which the product is installed. It is recommended the following tests are carried out :

- 1 Visual inspection of the metering display (every year)
- 2 Operation of output contacts (every 2 years)
- 3 Secondary injection of each element (every 5 years)

2 Defect Report Form

Form sheet for repairs and returned goods (fields marked with * are mandatory fields)

Sender:

* Name, first name:	Complete phone number (incl. country code):	Complete fax number (incl. country code):
Email address:	* Org-ID and GBK reference:	* AWV:

* **Order-/ reference-no (choosing at least 1 option):**

Order-no for repair:	order-/ delivery note-no for return of commission failure:	Beginning order-no for credit note demand:
----------------------	--	--

Information concerning the product and its use:

* Order Code (MLFB):	Firmware version: V	* Serial number:	
* Customer:	Product was in use approximately since:	Station/project:	Hotline Input no.:
Customer original purchase order number:	Delivery note number with position number:	Manufacturer:	

* **Type of order (choosing at least 1 option):**

<input type="checkbox"/> Repair	<input type="checkbox"/> Return of commission failure	<input type="checkbox"/> Credit Note
<input type="checkbox"/> Upgrade / Modification to ...	<input type="checkbox"/> Warranty repair	<input type="checkbox"/> Quotation (not repair V4 and current products! See prices in PMD)
	<input type="checkbox"/> For collection	

Type of failure:

<input type="checkbox"/> Device or module does not start up	<input type="checkbox"/> Mechanical problem	<input type="checkbox"/> Overload
<input type="checkbox"/> Sporadic failure	<input type="checkbox"/> Knock sensitive	<input type="checkbox"/> Transport damage
<input type="checkbox"/> Permanent failure	<input type="checkbox"/> Temperature caused failure	<input type="checkbox"/> Failure after ca <input type="text"/> hrs in use
<input type="checkbox"/> Repeated breakdown	<input type="checkbox"/> Failure after firmware update	

Error description:

<input type="checkbox"/> Display message: (use separated sheet for more info)	<input type="text"/>
--	----------------------

Active LED messages:

Faulty Interface(s), which?

Wrong measured value(s), which?

Faulty input(s)/output(s), which?

* **Detailed error description (please refer to other error reports or documentation if possible):**

* **Shall a firmware update be made during repair or mechanical upgrade of protective relays? (choosing at least 1 option)**

Yes, to most recent version

No

Yes, actual parameters must be reusable

repair report:

Yes, standard report (free of charge)

Yes, detailed report (charge: 400EUR)

Shipping address of the repaired/upgraded product:

Company, department

Name, first name

Street, number

Postcode, city, country

Date, Signature

Please contact the Siemens representative office in your country to obtain return instructions.

7PG26 DAD

High Impedance Relays

Document Release History

This document is issue 02/2010. The list of revisions up to and including this issue is:

Pre release

02/2010	Document reformat due to rebrand

Software Revision History

--	--	--

The copyright and other intellectual property rights in this document, and in any model or article produced from it (and including any registered or unregistered design rights) are the property of Siemens Protection Devices Limited. No part of this document shall be reproduced or modified or stored in another form, in any data retrieval system, without the permission of Siemens Protection Devices Limited, nor shall any model or article be reproduced from this document unless Siemens Protection Devices Limited consent.

While the information and guidance given in this document is believed to be correct, no liability shall be accepted for any loss or damage caused by any error or omission, whether such error or omission is the result of negligence or any other cause. Any and all such liability is disclaimed.

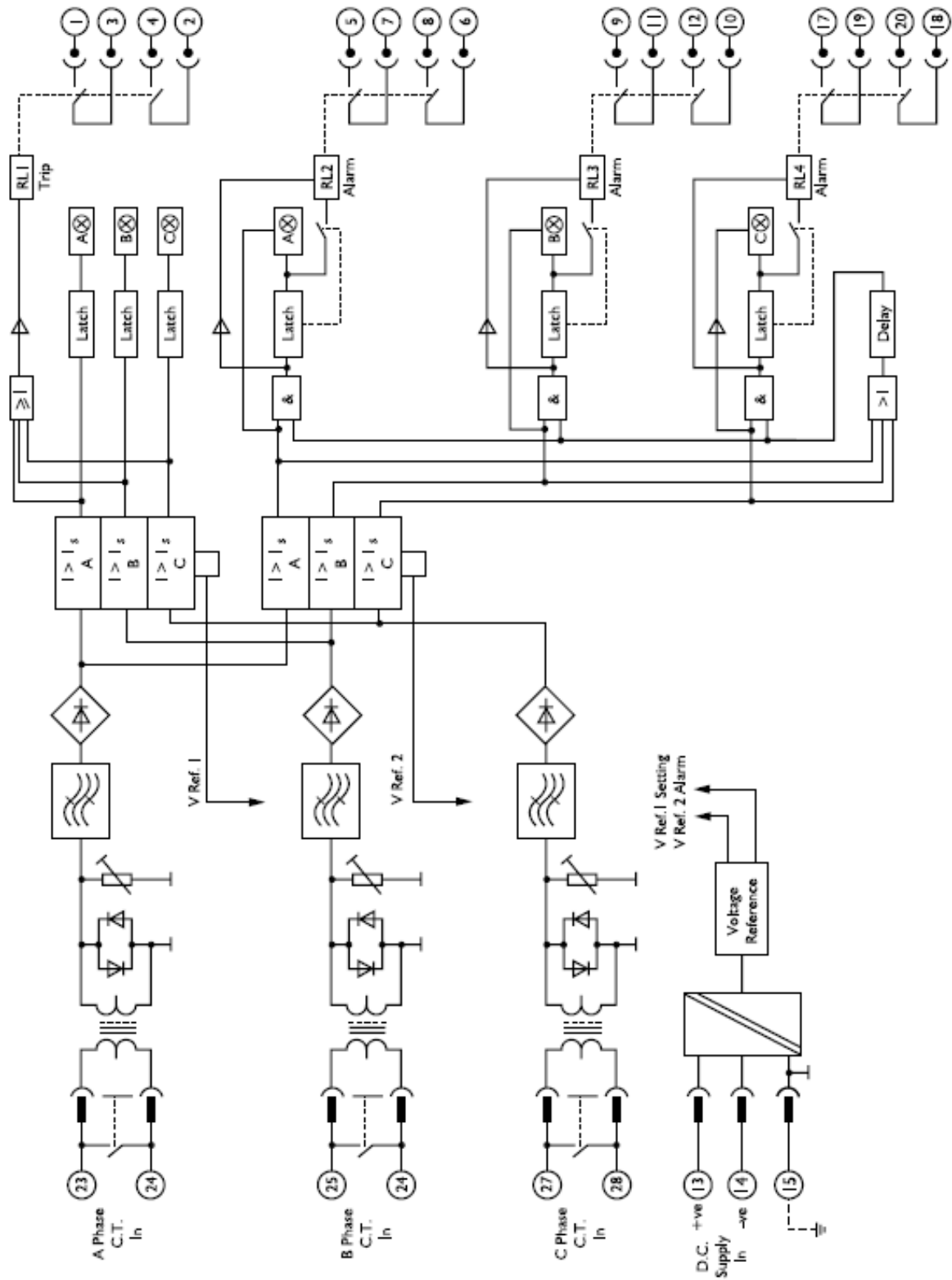

Figure 1 Connection Diagram of DAD3 Relay

Published by and copyright © 2010:

Siemens AG
Energy Sector
Freyeslebenstrasse 1
91058 Erlangen, Germany

Siemens Protection Devices Limited

P.O. Box 8
North Farm Road
Hebburn
Tyne & Wear
NE31 1TZ
United Kingdom
Phone: +44 (0)191 401 7901
Fax: +44 (0)191 401 5575
www.siemens.com/energy

For more information, please contact our
Customer Support Center.

Phone: +49 180/524 70 00
Fax: +49 180/524 24 71 (Charges depending on provider)
E-mail: support.energy@siemens.com

Power Distribution Division Order No. C53000-G7076-C14-1
Printed in Fürth

Printed on elementary chlorine-free bleached paper.

All rights reserved.

Trademarks mentioned in this document are the property of Siemens AG, its affiliates, or their respective owners.

Subject to change without prior notice.

The information in this document contains general descriptions of the technical options available, which may not apply in all cases. The required technical options should therefore be specified in the contract.